

**Ambush Hunting in Spiders**  
with special reference to the hunting behaviour of *Segestria florentina*, Rossi and the feeding of *Sericopelma rubronitens*,  
Ausserer (Araneae)

Arthur E. Decae

*National Museum of Natural History, Leiden. The NETHERLANDS.*

**Introduction**

"Free hunting", the active pursuit of prey, is traditionally seen as the most primitive form of spiders' hunting behaviour (e.g. Buchli, 1969; Foelix, 1979; Gertsch, 1979). I believe however there is no more than an intuitive base for this hypothesis and I personally rather imagine the first spiders to have been "ambush hunters", not unlike the majority of Orthognathe spiders today. Like most orthognaths, the earliest spider, in my imagination, inhabited a permanent nest that among other things functioned as a hide-out from which passing prey was ambushed.

The arguments I can present for my line of thought are:

- ambushing prey from a more or less permanent nest is very widely spread in the spider world and found in Liphistiomorphae, Mygalomorphae and Araneomorphae alike.
- the form in which ambushing is exhibited in all these groups of spiders is rather similar and stereotype.
- the elements of ambush hunting and the sequence in which they are performed are found back in the more specialized "web hunting".

**Ambush hunting**

A typical ambush hunter will lay in wait in the entrance opening of its nest. In this position it acts as a jack-in-the-box to the passage of prey. The spider dashes forward to grab passing prey after which it instantly retreats. The whole action of prey capture often takes less than half a second. In a flash the prey is simply dragged to the spider's nest where it will

Contrary to vertebrate predators, ambush hunting spiders do not use vision, olfaction or sound to detect prey (Coyle, 1986). So what senses do play a role in the flash attacks of ambushing spiders ?

A casual experiment I carried out during my holidays last year in Bretagne with the locally common and typical araneomorph ambush hunter *Segestria florentina*, indicated that at least three sensory systems sequentially come into action.

Two of these, a sense for substrate vibration or movement and a sense of "touch" give instant information about the prey and act during the flashing prey capture sally just described. The third, a contact chemical sense (taste) functions more slowly, after the spider has retreated into its nest. This sense will tell the spider if a prey is actually edible.

### **Prey capture behaviour in *Segestria florentina* (Fig. 1)**

Prey capture in *S. florentina* is largely a nocturnal activity. In the daytime the spiders reside in the deeper parts of their tube-nests. They will come to the entrance however in reaction to vibrations or movements that may indicate the presence of prey within capture range. If alerted by such movements *S. florentina* in Bretagne will make an effort to capture prey even in bright sunlight, so at least in the northern populations, the species is not strictly nocturnally active.

Prey capture can be artificially invoked by carefully touching the silken fishing lines that extend from the entrance rim, with a thin stick, grass blade or other fine tool. This system of getting a spider into aggressive action is probably known from personal experience by every arachnologist in the world because it works for all ambushing and web building species.

I myself had sticks and little balls of cottonwool captured by all sorts of mygalomorphs: theraphosids, barychelids, ctenizids and diplurids alike and by numerous araneomorphs as well.

Fig. 1.

Ethogram hunting behaviour *Segestria florentina*

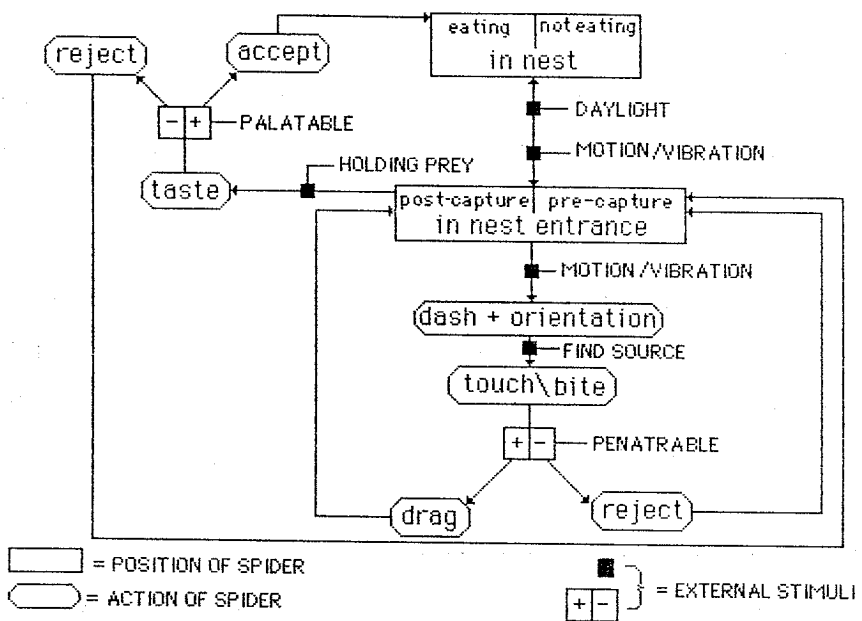

I always wonder why no other spider predator than the arachnologist has found out about this simple trick to get a defensively hidden spider into the open.

At dusk *S. florentina* takes up a position in the nest entrance, resting the tarsi of the anterior legs on the proximal ends of the fishing lines. The spider is now very alert to react to any movement within sensing range. In reaction it will dash forward from its hide-out to pounce on anything, within certain size limits, that moves inside the capture zone. This zone extends for some centimeters in all directions around the entrance of the nest.

### Movement and vibrations

The fact that the spider quite indiscriminantly attacks all sorts of moving objects indicates that the vibration signal, that triggers prey capture behaviour, contains rather coarse-grade information. It tells the spider where the prey is located and something about its

approximate size (moving large objects cause the spider to withdraw into the nest instead of to attack) but it apparently carries little information about the identity of the moving object. The limited information on which spiders depend to detect prey makes them prone to make mistakes. I have witnessed an illustrative natural mistake once, when a large Panamanian birdspider (*Sericopelma rubronitens*) attacked a leaf, that drifted from a jungle tree to touch the ground only centimeters from the lurking spider. It took this spider several seconds to find out that the leaf was not spider-food and could be discarded. But apparently the risk involved in making such mistakes is sufficiently remote for most of the spider world to live with it for millions of years.

According to Mark Stowe (1986), it is the speed at which a spider arrives at the prey that is critical to the capture success. This probably outweighs the risk of making mistakes and makes the spider act on limited information.

## **Touch**

The first opportunity to learn more about the identity of the prey comes when spider and prey make contact. Using its palps *S. florentina* holds the prey down for an instant before it strikes with its fangs. Coyle & Ketner (1990) this year published a more detailed description of analogous behaviour in the diplurid genus *Ischnothele* and I myself have observed virtually similar attack behaviour in several trapdoor spider species (fam. Ctenizidae).

It is about the initial contact between spider and prey that my holiday experiment may have yielded some interesting information.

A population of 14 adult female *S. florentina* spiders, living on the walls of a countryhouse near Matignon (Bretagne / France) served as the test group. The hunting behaviour as described above, was studied by hand feeding these spiders freshly killed flies that were mounted on the top of a very fine wooden stick. All 14 spiders captured the fly in the described way and accepted it as food. This gave me the opportunity to experiment also with

other types of prey. I chose to offer the spiders "fake-prey" of soft polystyrene plastic and hard polyethene plastic. Both plastics were cut in small prisms of 3 X 3 X 7 mm and furnished with a small hole in one of the sides to mount it on the stick. For a couple of days the spiders were presented with a fake-prey within their capture ranges around dusk, just after they had taken up prey capture positions at the nest entrances.

I found that hard plastic (polyethene) objects were virtually always instantly rejected at the spot, while soft plastic (polystyrene) objects were generally dragged into the spiders nests (Fig. 2) to be rejected seconds later. As I said dead flies were always dragged into the nest, accepted as food and eaten.

Fig. 2

Results of experiments with *Segestría florentina*, offering the spiders hard plastic (polyethene) and soft plastic (polystyrene) "prey objects". Drags, gives the number of times the plastic prey object was dragged into the spider's nest. Rejections, gives the number of times the spider rejected the plastic prey object at the location of first contact.

	drags	rejections	
hard plastic polyethene	2	28	30
soft plastic polystyrene	29	9	38
	31	37	68

$$\text{Chi}^2 = 30.03 ; P < 0.002$$

From this it seems that the hardness of the integument of the prey is measured by the spider as a first check of the prey's suitability as food. Because both polyethene and polystyrene objects were always bitten before they were either dragged towards the nest or rejected, I have the impression that the ability to drive the fangs through the integument is an important source of information for the spider.

### **Taste**

As I said the polystyrene prisms were mostly dragged into the nest and rejected after a few seconds. Apparently it takes the spider some time to learn if the captured object is edible or not. Den Otter (1974) working with *Sericopelma rubronitens* has shown that a contact chemical sense (taste) affects the spider's decision to eat or reject prey.

With this same species (*Sericopelma rubronitens*) I tested if immobile prey would anyhow be recognized as food. I did this experiment during my stay in Panama in 1983. Then I offered freshly killed grasshoppers to these birdspiders. The grasshoppers were killed by placing them in the freezer for a couple of hours. Before offering the dead grasshoppers to the spiders, they were allowed to defreeze and obtain the temperature of the environment. The dead grasshopper was placed carefully, not to disturb the spider, on the bottom of the container in which the spider was kept, and left alone until the spider would "detect" it. It was found that the dead grasshoppers were indiscriminantly accepted as food when the spiders happened to stumble on them accidentally. When I placed dead grasshoppers near the burrows of free living *Sericopelmas* in the field they were also accepted as food when the spiders accidentally touched them.

From these observations it became clear that movement of the prey is not essential to be recognized as food and that, after prey-capture, a different sensory system tells the spiders if the captured object is edible. The fact that the spiders actually had to touch the dead grasshoppers lying in their cages or in their hunting ranges, before picking them up to eat, indicates that food recognition acts by some "contact sense".

A "contact chemical" (taste) stimulus is the most likely stimulus type to recognize food (at least in human perception), although recognition by touch (shape or other surface characters of the prey) can not be a priori excluded.

To investigate this possibility I offered my spiders a wide range of artificial prey of different shape, size and texture. Various sorts of meat, sausage and also banana wrapped in paper as a ball, a cylinder or a more or less prismatic block, were offered to the spiders. All of these shapes and substances were accepted as food. Ball-shaped and sausage-shaped rolls of cotton wool drenched in water were also picked up by the spiders and handled as if they were prey. Dry paper rolls and cotton wool balls placed with the spiders however were consequently ignored. The observation suggests that spiders recognize food finally by taste!

So in summary, three sensory systems guide ambush hunting spiders in the collection of food.

- 1) Substrate vibrations inform the spider about the presence and the location of the prey and trigger prey capture behaviour. The signals are probably sensed through the lyriform organs on the legs (Barth 1978).
- 2) A sense of touch, most probably the ability to penetrate the integument of the prey with the fangs, gives initial information about the identity of the prey.
- 3) Contact chemical information, probably through mediation of the chemo-receptive hairs as described by Foelix (1970) and Harris and Mill (1977), finally tells the spider if a prey is edible.

## Literature

- Barth F. G. 1978 Slit sense organs: "strange gauges" in the arachnid exoskeleton. Symp. Zool. Soc. London 42: 439-448.
- Buchli H. 1969 Hunting Behavior in the Ctenizidae. Am. Zool. 9: 179-193.
- Coyle F. A. 1986 The Role of Silk in Prey Capture by Nonaraneomorph Spiders. In Spiders, webs, behavior and evolution, ed. W. A. Shear. Stanford University Press.
- Coyle F. A. & N. D. Ketner 1990 Observations on the prey capture of the funnelweb mygalomorph spider genus *Ischnothele* (Araneae, Dipluridae) Bull. Br. arachnol. Soc. 8 (4): 97-104.
- Den Otter C.J. 1974 Setiform sensilla and prey detection in the bird spider *Sericopelma rubranitens*, Ausserer, 1871 (Araneae, Theraphosidae). Neth. J. Zool, 24: 219-235.
- Foelix R. F. 1970 Chemosensitive hairs in spiders. J. Morphol. 132: 313-334.
- Foelix R. F. 1979 Biologie der Spinnen. G. Thieme Verlag, Stuttgart.
- Gertsch W. J. 1979 American Spiders, sec. edition. Van Nostrand Reinhold Comp. New York.
- Harris D. J. & P. J. Mill 1977 Observations on the leg receptors of Ciniſlo (Araneae, Dictinidae) II Chemoreceptors. J. Comp. Physiol. 119: 55-62.
- Stowe M. K. 1986 Prey Specialization in the Araneidae. In Spiders, webs, behavior and evolution, ed. W. A. Shear. Stanford University Press.
-